

# Harry Potter

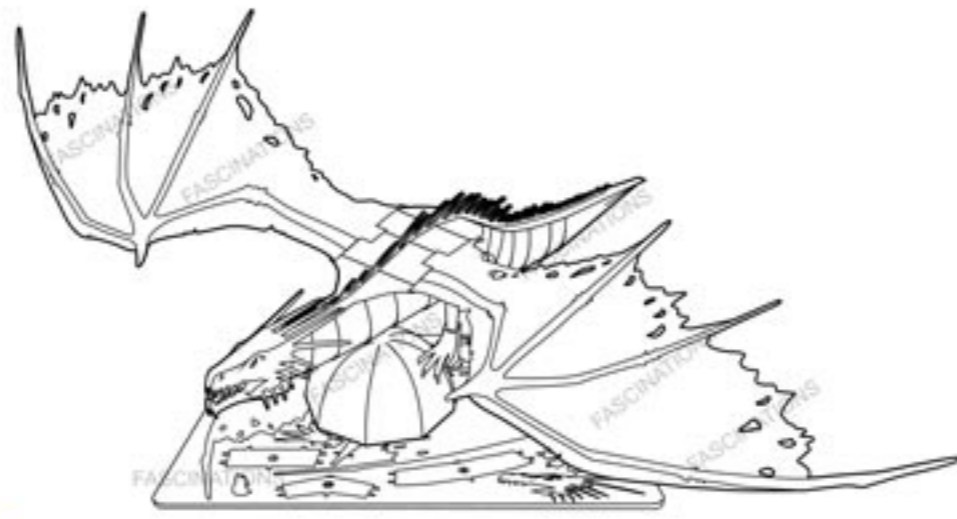

## GRINGOTTS DRAGON

Item No. MMS443

# METAL EARTH<sup>®</sup>

3D METAL MODEL KITS

360°  
view



It is highly recommended that you visit [www.fascinations.com/360/mms443](http://www.fascinations.com/360/mms443) to see the completed model before assembling your own

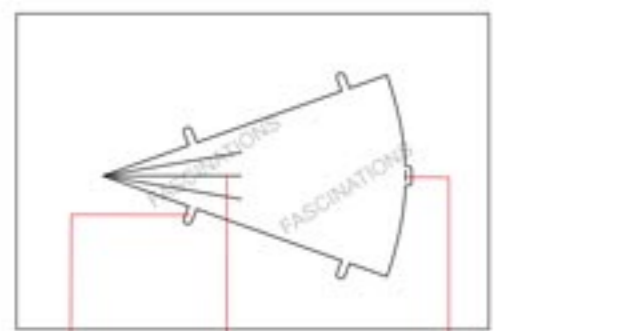

Insertion tabs are inserted and then folded  
Fold lines can be seen as shown here  
Insertion holes

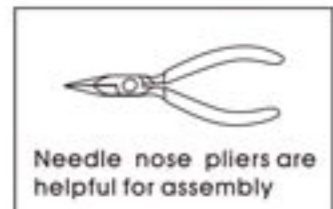

Needle nose pliers are helpful for assembly

Legends:

**E** Engraved side

**NE** Non-engraved side

Attention point

### To create the best connections

Insert tab and bend 90 degrees for most visible areas

Insert tab and twist 90 degrees is best in some areas to ensure a tight connection

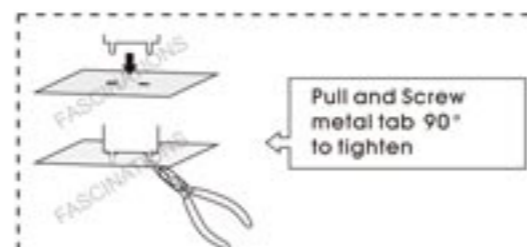

### Metal sheets

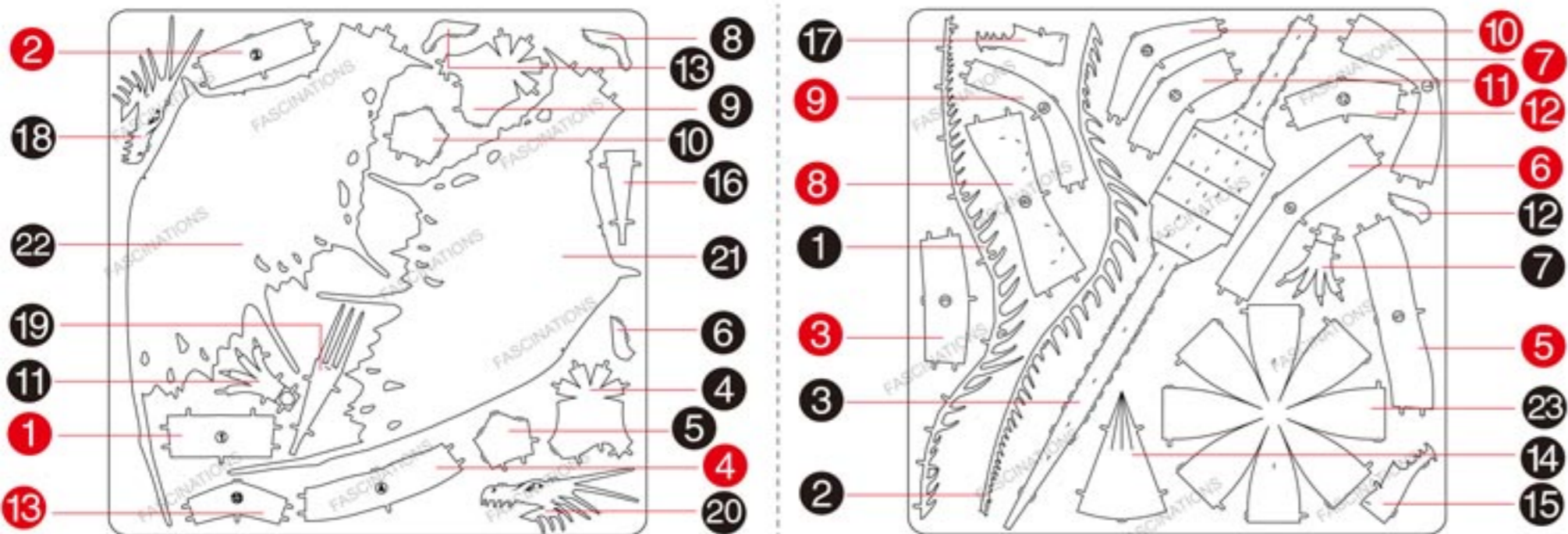

In order to avoid possible injury from sharp edges, please carefully discard the metal sheet after parts have been removed

### Assembly Flow Chart

CAUTION: THIS MODEL HAS MANY SHARP POINTS. ASSEMBLE WITH CARES

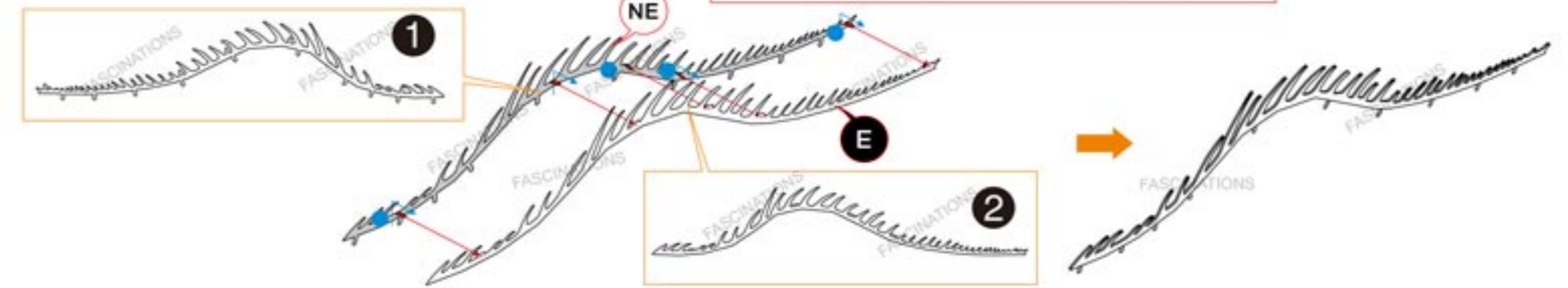

Tip: start connecting from the left, one tab at a time

