

METAL EARTH[®]

3D METAL MODEL KITS



360°
view

It is highly recommended that you visit www.fascinations.com/metalearth360/mms271 to see the completed model before assembling your own

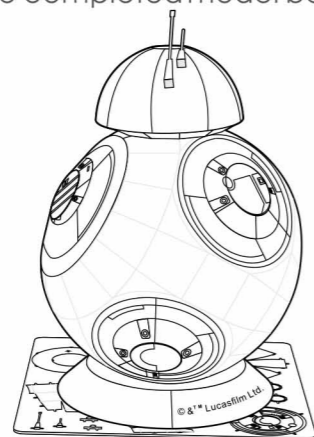

mms271

To create the best connections

Insert tab and bend 90 degrees for most visible areas

Insert tab and twist 90 degrees is best in some areas to ensure a tight connection

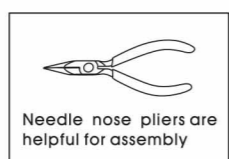

Legends:

- Engraved side
- Non-engraved side
- Attention point

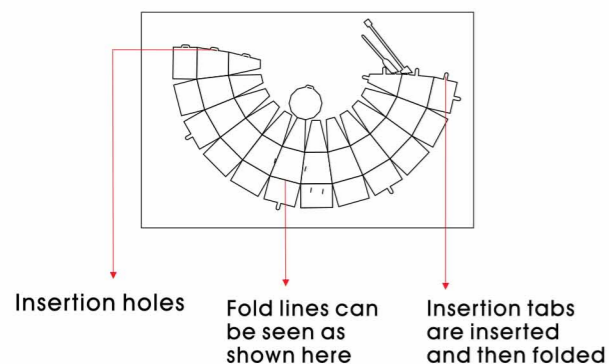
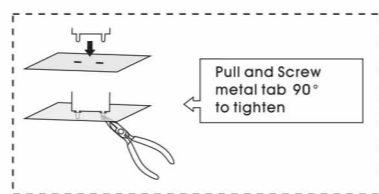

Insertion holes

Fold lines can be seen as shown here

Insertion tabs are inserted and then folded

Metal sheets

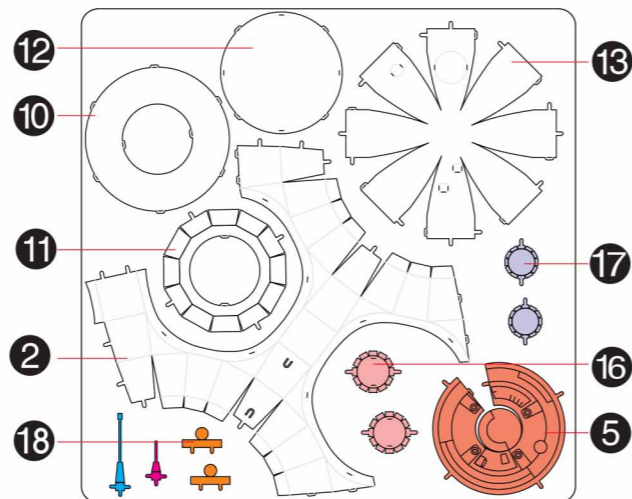
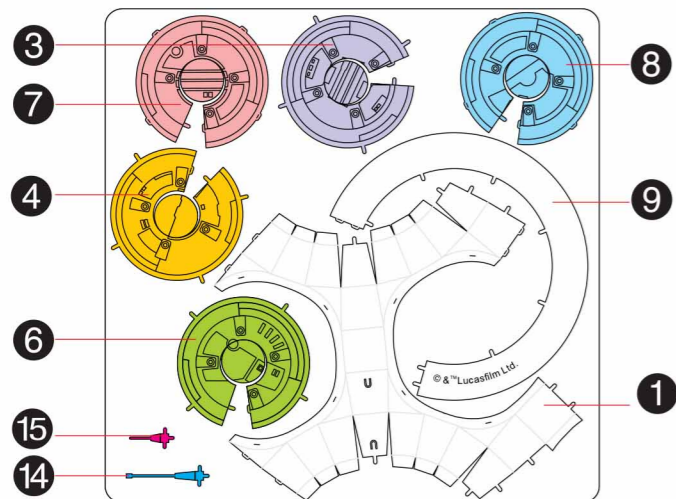

In order to avoid possible injury from sharp edges, please carefully discard the metal sheet after parts have been removed

Assembly Flow Chart

