

# METAL EARTH™

## 3D LASER CUT MODELS

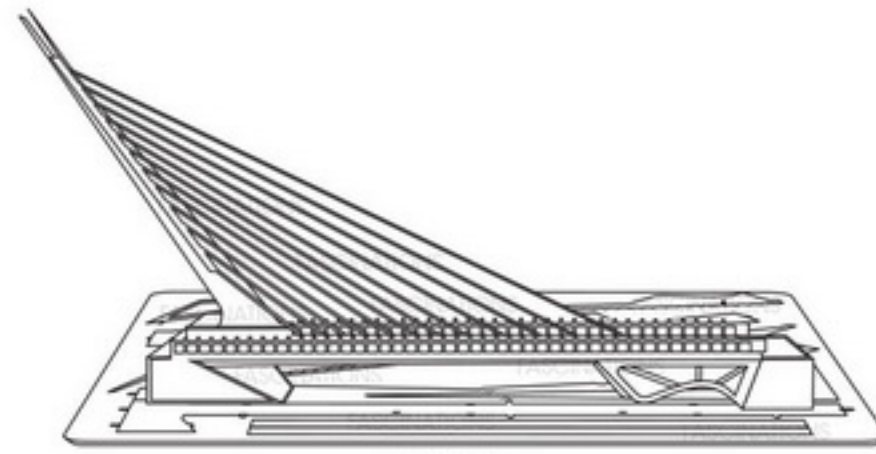

It is highly recommended that you visit [www.fascinations.com/metalearth360/mms031](http://www.fascinations.com/metalearth360/mms031) to see the completed model before assembling your own



mms031

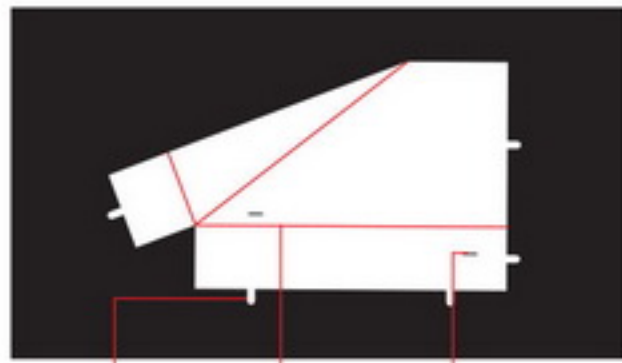

Insertion tabs are inserted and then folded  
 Fold lines can be seen as shown here  
 Insertion holes

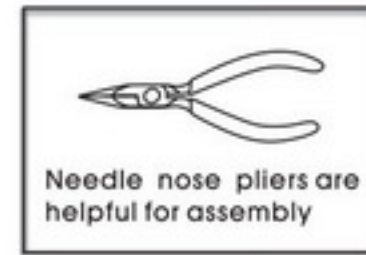

Metal sheet

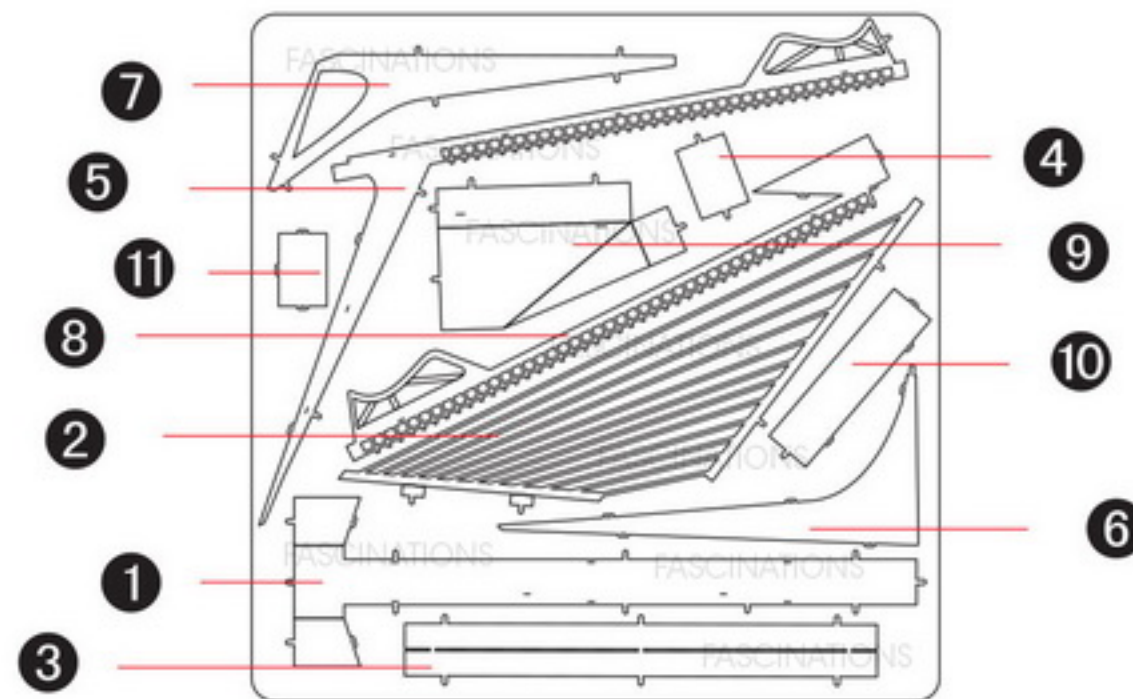

### To create the best connections

Insert tab and bend 90 degrees for most visible areas

Insert tab and twist 90 degrees is best in some areas to ensure a tight connection

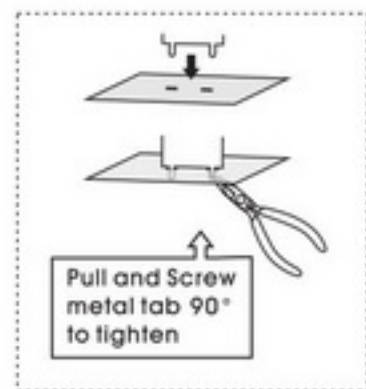

In order to avoid possible injury from sharp edges, please carefully discard the metal sheet after parts have been removed

### Assembly Flow Chart

